

PM STEPPING MOTOR MOD.42BY100B01(S42M100S33)

□ 接线图 COLOURS OF LEAD WIRES

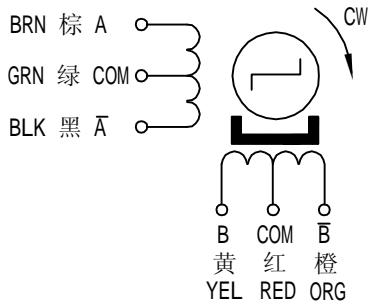

DRIVE MODE:(4-2)

STEP	PIN NO.1	2	3	4	5	6
1	0	1	X	0	1	X
2	0	1	X	X	1	0
3	X	1	0	X	1	0
4	X	1	0	0	1	X

— CW(SEE FROM THE SHAFT)
1=Positive Voltage 0=GND X=Open

□ 外形图 DIMENSIONS(unit=mm)

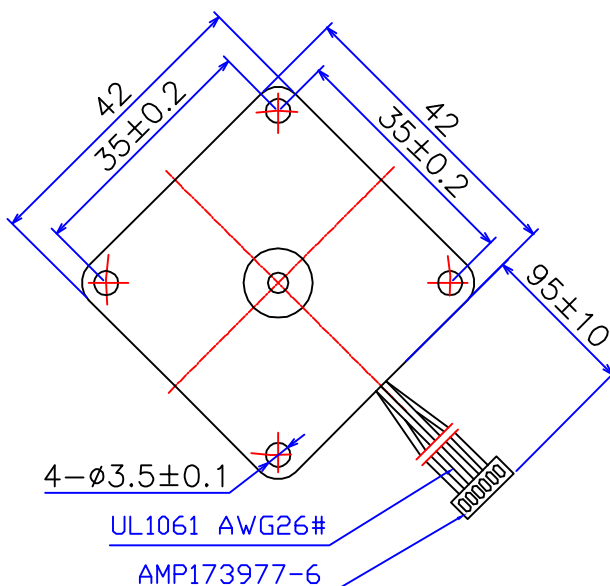
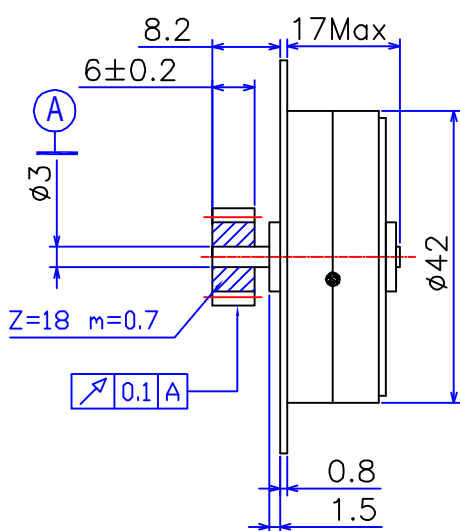

Wire Requirement Do Outer diameter: $0.85 \leq D \leq 1.05$

□ 标准规格 Standard Specifications

额定电压	Rated Voltage	12 V	COMMENT
额定电流	Rated Current	0.16 A	
相数	No. of phases	4	
步距角	Step Angle	$3.6^\circ \pm 7\%$	
激磁方式	Excitation	4-2 Unipolar	
使用温度	Operating Temperature Range	$-10^\circ\text{C} - 55^\circ\text{C}$	
储存温度	Storage Temperature Range	$-40^\circ\text{C} - 70^\circ\text{C}$	
线圈电阻/相	Resistance per Phases	$12.5 \Omega \pm 7\% (20^\circ\text{C})$	
保持转矩	Holding Torque	370(5V 4-2)g.cm Min	
定位转矩	Detent Torque	100 g.cm Max	
转动惯量	Rotor Inertia	14.8 g.cm ²	
耐压	Dielectric Withstand Voltage	500V(50Hz,1min) Min	
重量	Net Weight	100 g	

旧底图总号

底图总号	标记	处数	分区	更改文件号	签名	年.月.日	常州宝来电器有限公司
	设计		070116	标准化			
日期	签名	审核					Tel:0519-88372126 Fax:0519-88372780
		工艺		批准			

格式 (1)

制图:

描图:

幅面: 4[#]